

SMHI operational HIRLAM

EWGLAM 2003 6 - 9 October

Lars Meuller SMHI

Operational HIRLAM

- 4 forecasts every day.
HIRLAM44 and HIRLAM22
00z, 06z, 12z, 18z
Analysis and +48h forecast
- 2 hour obs cut off time
- ECMWF preprocessing
SYNOP, TEMP, PILOT,
BUOY, AIREP, AMDAR
- ATOVS, VAD-winds passive



HIRLAM44

- 40 levels, 0,4° (44km)
horizontal resolution
- 202x178 gridpoints
- ECMWF boundaries every 3h - BC
- Semi-Lagrangian time stepping
12 min

HIRLAM22

- 40 levels, 0,2° (22km)
horizontal resolution
- 162x 142 gridpoints
- HIRLAM44 boundaries
- Semi-Lagrangian time stepping 6 min

Hirlam system

HIRLAM version 5.1.4

- 3D-VAR analysis
- DFI initialisation
- ISBA (surface scheme)
- CBR (turbulence)
- Kain-Fritsch (convection)
- Rasch-Kristjansson (large scale)
- MPI parallel

PLANS

- 4D-VAR on limited area
- treatment of snow in ISBA
- increased resolution
22 + 11 km horizontal
60 vertical levels
- new observations
ATOVS radiances - EARS
VAD wind profiles
GPS humidity
- non hydrostatic model

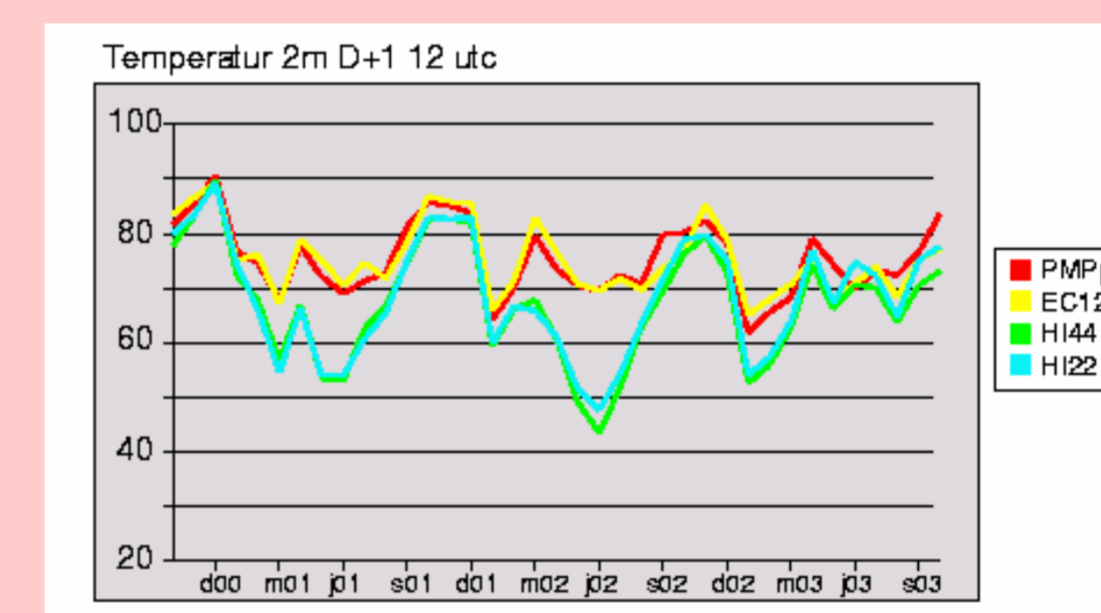

Computer system at the National Supercomputing Centre at Linköping University



www.nsc.liu.se

Operational :

PC-cluster **HOME-MADE**
Linux RedHat
Intel, GNU and PGI compilers
ScaMPI, MPICH, LAM mpi-lib
Intel MKL – Math Kernel Library
Open PBS batch system

Next cluster for
4D-VAR
discussions started

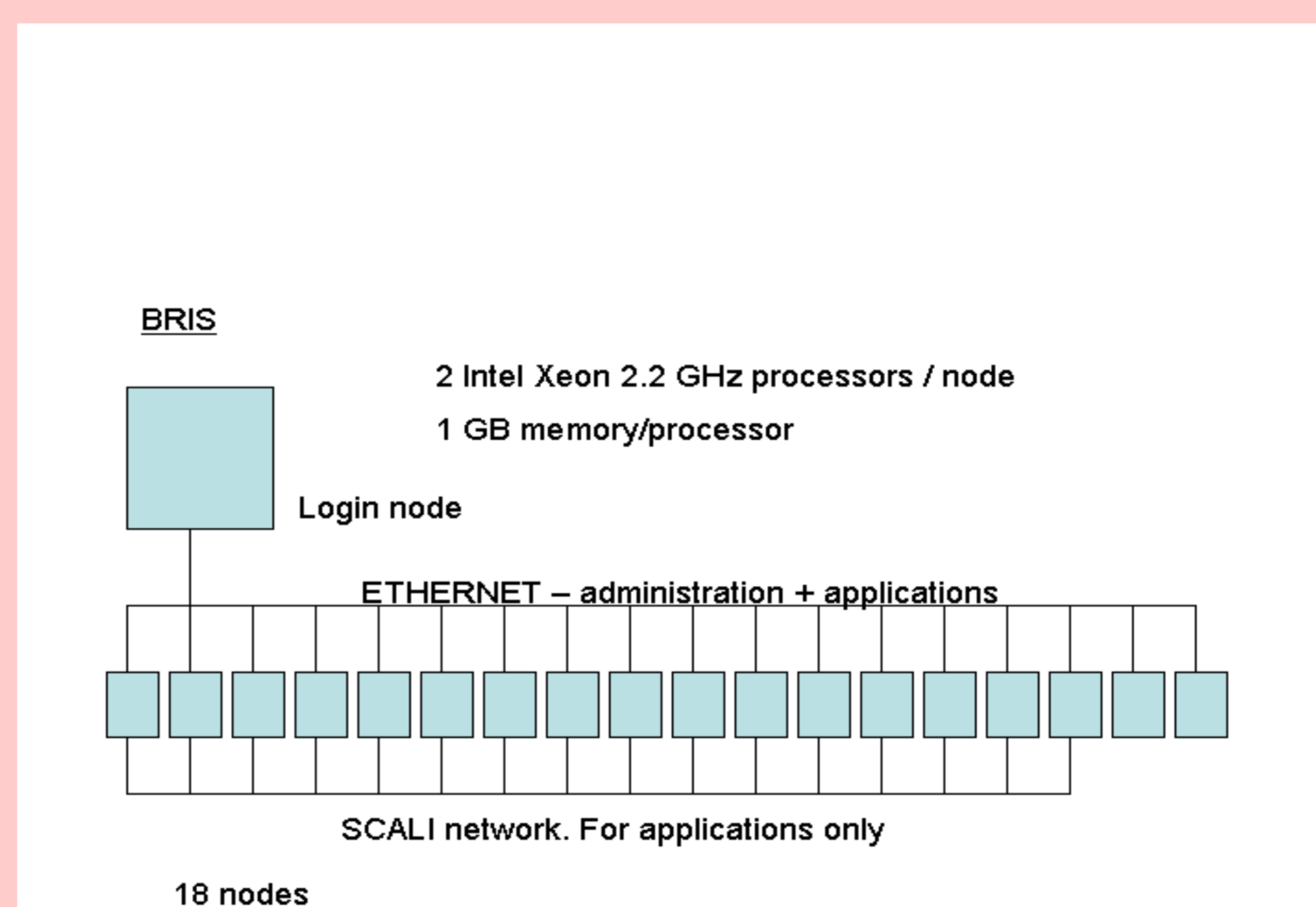

Backup: SGI ORIGIN 3800

- 128 MIPS R14000 processors
- 128 GFLOPS peak performance
- 128 GB shared memory
- IRIX operating system
- LSF batch system

